



AGENDA OF THE OPEN HOUSE
OF THE CITY COUNCIL
AND ROADS & STREETS COMMITTEE
CITY OF BIRCHWOOD VILLAGE
WASHINGTON COUNTY, MINNESOTA
June 3, 2019
6:30 P.M.

REGULAR AGENDA

- A. Lake Links Trail Discussion – Birchwood Village Section*
 - a. Review and Discuss Route and Design Options
 - b. Public Question and Answer

ADJOURN

* Denotes items that have supporting documentation provided

WELCOME TO THE LAKE LINKS TRAIL OPEN HOUSE (BIRCHWOOD)

PLEASE: 1) Read the options below, 2) View the corresponding sketches, and 3) Submit your preferences or your own design in the space provided on the backside.

Options 1-3 below explain 7 different proposals that were discussed at the May 6, 2019 Joint Birchwood Village City Council / Roads Committee Meeting with the Lake Links Association. Each proposal starts at the Birchwood/Mahtomedi line. Mahtomedi has already decided to build an elevated pedestrian/bike lane with two vehicle lanes on the south side of the road.

Option #1. No change. This represents the current layout. Bike and walk lanes on both sides of road. Mahtomedi would need to create an interface at the city line to safely transition walkers and bikers into Birchwood. *See Sketch #1.*

Option #2. Change made ONLY from city line to Jay St. Two way traffic on south side of road and 8-10 foot walking/biking path on lake side of road. Both Options A and B would include adding drainage and a narrow (18-24 inch) concrete edge (not a curb) on the south side for pavement stability.

- A. *Elevated pathway/gentle curb for bikers and walkers (similar to other areas of the trail). *See Sketch #4.*
- B. *Same elevated pathway only for pedestrians. *See Sketch #4.*
- C. Same design but no elevated pathway/curb for bikers and walkers (remain at street level). *See Sketch #3.*
- D. Same as Option C but limited to pedestrians only. *See Sketch #3.*

**For comparison, the elevated path on Lake Ave in White Bear Lake is 12 feet.*

Option #3. Continue an 8-10 foot walking/biking lane on lake side of road all the way from the city line to the 3-way intersection of Hall/Cedar at Wildwood. This plan would not include an option for an elevated pathway. Drainage and narrow (18-24 inch) concrete edge (not a curb) would be built for stability. *See Sketch #3.*

- A. For bikers and walkers.
- B. For pedestrians only.

Options 1-3:

- These options tried to take into account the whole range of options while still preserving the scenic beauty of the village. Please review and give comments on the sheets provided as to which plans you like or don't and why. Feel free to add options or things you want considered as well.
- These options do not exceed the parameters of the existing pavement (except an 18-24 inch concrete re-enforcement edge if the car traffic lanes are pushed all the way to that side). Thus, parking conditions will remain the same as is.
- No significant trees will be removed.
- All improvement costs will be covered by Lake Link's legislative funds before we proceed with any plans.

Electronic versions of the sketches and the Lake Links Assoc.'s explanation of each sketch can be found here: <https://www.cityofbirchwood.com/notices>

Additional Options:

- Sketch #2 and 5-8 were created by the Lake Links Association as additional considerations. These options are being shown for the first time tonight.
- Please draw and/or describe your suggested option, if any below.

YOUR RESPONSE:

What are your preferences? Write them here or draw your own design (don't forget to turn it in before you leave):

THANK YOU!

Electronic versions of the sketches and the Lake Links Assoc.'s explanation of each sketch can be found here: <https://www.cityofbirchwood.com/notices>

SKETCH 1 - CURRENT CROSS-SECTION

HALL AVENUE - Between #707 and #709
Present Contion - (2) 50" shoulders, (2) 118" lanes

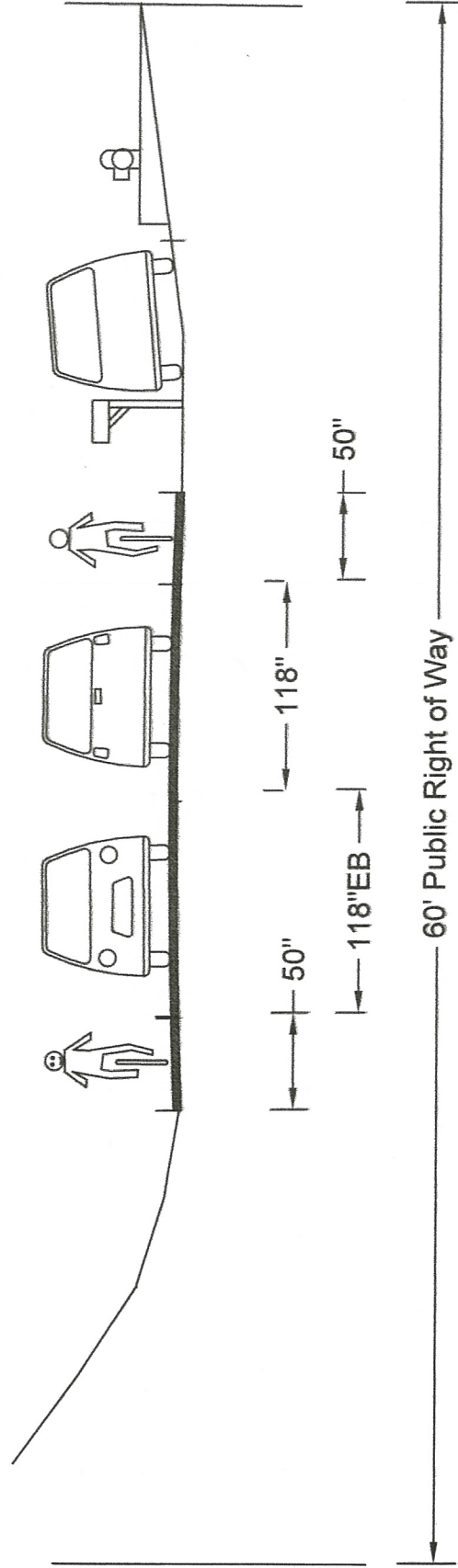

SKETCH 3 - Add 2' asphalt shoulder on south side
no change on north, 2' shoulder, (2) 9' lanes,
10' marked trail

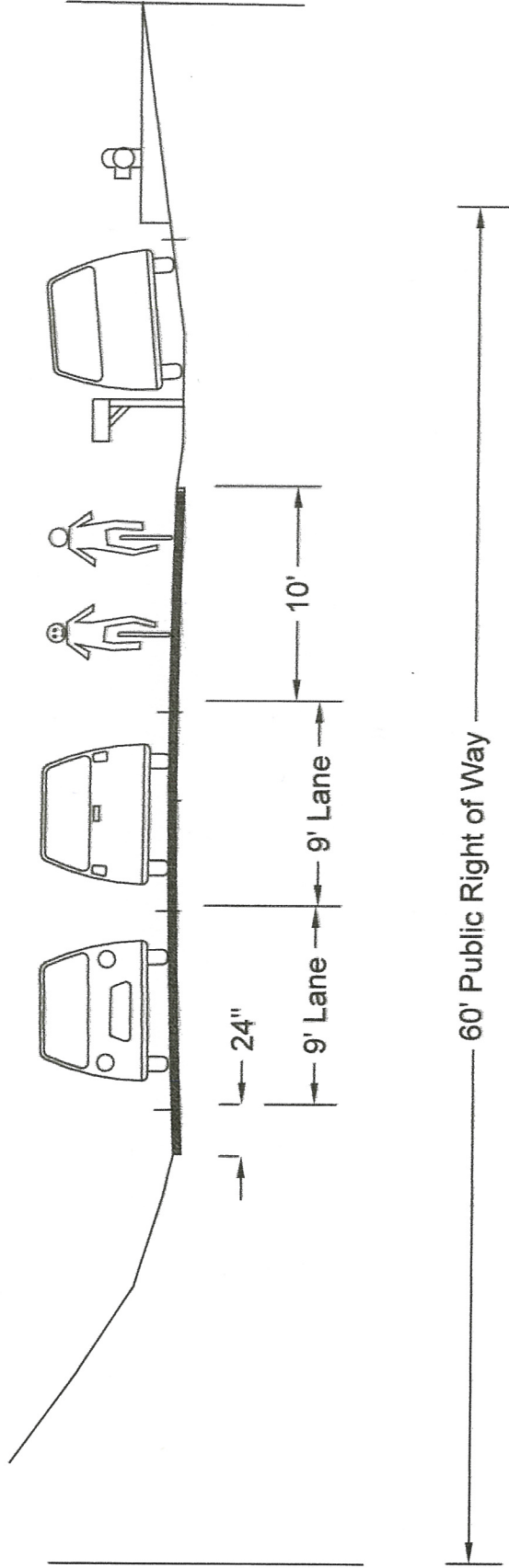

Sketch 4 - No change to south side
Surmountable curb separates 10' trail
from traffic lanes

